

电动汽弹枪

FULL · SEMIAUTO

R-4

请仔细阅读说明书



在操作之前必需读熟这些说明书

Always read through this manual before operation.



警告 WARNING



仅限18岁及以上者
Only for 18 years
of age or older

仅限18岁及以上者使用此枪
Operation only for 18 years of age or older



注意危险
Injury caution

使用前请仔细阅读说明书
Always read through the instruction manual before operation



仔细阅读说明书
Careful reading of
Handling cautions
and
instruction manual

使用前请仔细阅读说明书
Always read through the HANDLING CAUTION AND INSTRUCTION MANUAL carefully before operation.
Operation requires strict observation of handling instructions.

FOR AGES: 18 AND UP

7

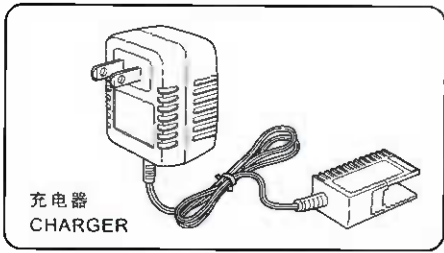

充电器
CHARGER

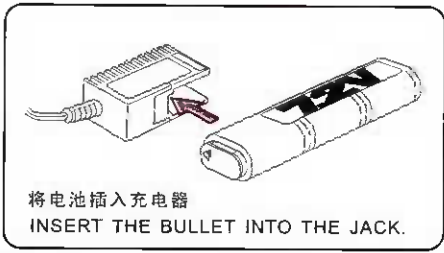

将电池插入充电器
INSERT THE BULLET INTO THE JACK.

1 各部分名称 NAME OF EACH PART

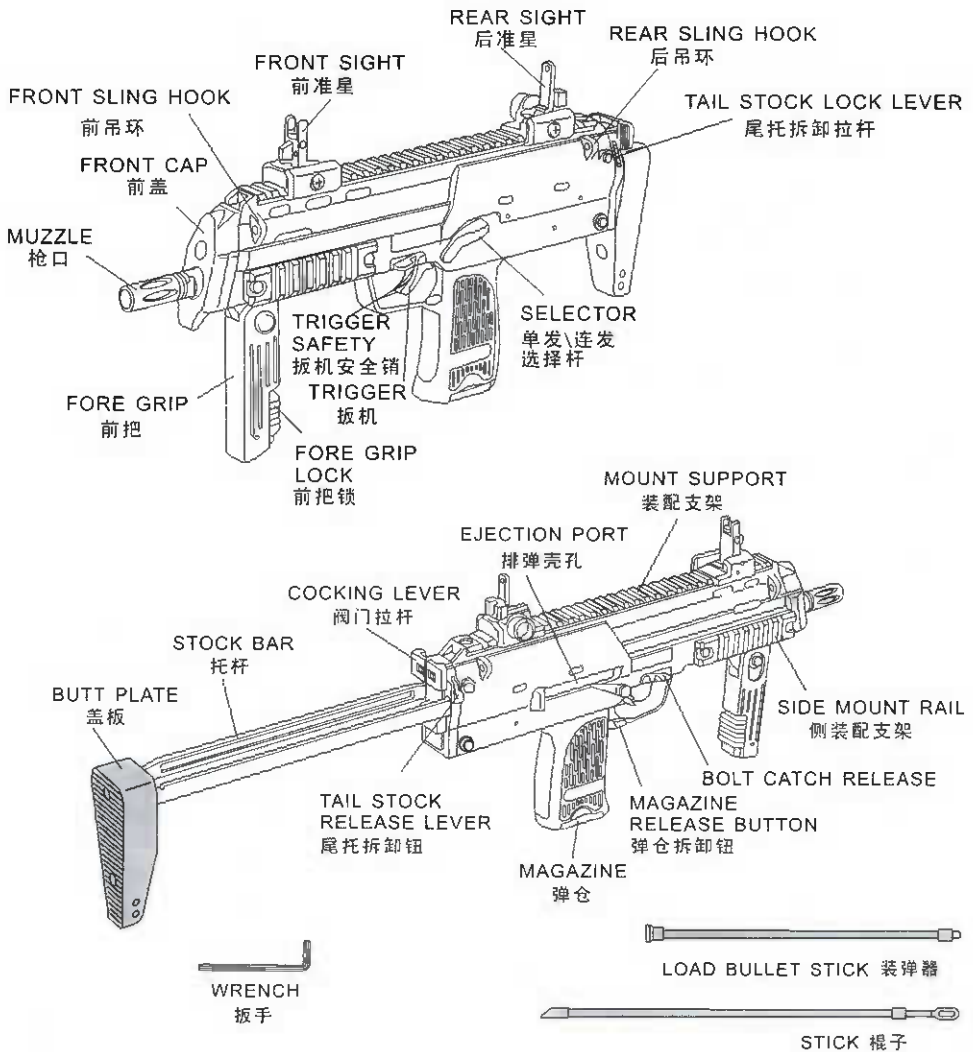

2 单发\连发 SINGLE \RUNNING SHOOT

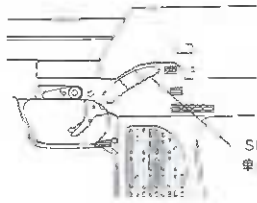

SELECTOR
单连发选择杆

NEVER OPERATE THE SELECTOR WHILE PULLING THE TRIGGER. OTHERWISE, MALFUNCTIONS MAY OCCUR. PULLING THE TRIGGER WITH THE SELECTOR BEING SET TO SAFE MAY DAMAGE THE GUN.

请勿在扣扳机同时操控单连发选择杆。否则可能会对枪造成损害并造成事故。

	<p>SAFETY STATE SET THE SELECTOR TO THE SAFE POSITION WHILE YOU ARE NOT USING IT. 安全 在不使用枪时将选择杆拨在“安全”位置上</p>
	<p>SINGLE SHOT ONE BULLET ONE TIME. 单发,每发一弹</p>
	<p>RUNNING SHOT MORE BULLET ONE TIME. 连发 每发多弹</p>

3 弹仓 MAGAZINE

PULL THE MAGAZINE UPWARDS UNTIL A CLICK SOUND IS HEARD.
往上推弹仓直至听到“喀嚓”一声。

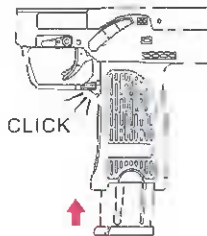

LOAD BB BULLET AS ILLUSTRATION.
如图所示装BB弹

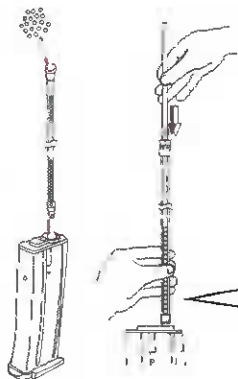

PRESS THE BUTTON TO TAKE THE OBSTRUCT.
按此按钮取出阻塞弹

PRESS THE MAGAZINE RELEASE BUTTON DOWNWARDS TO DISASSEMBLE THE MAGAZINE.
向下拨弹仓拆卸按钮拆卸弹仓



INSERT THE STICK INTO THE TUBE TO PUSH THE BULLETS INTO THE MAGAZINE.

将棍子插入装弹器辅助装弹
THE MAGAZINE CONTAINS NOT MORE THAN 40 PCS BULLETS.
PLEASE DON'T LOAD THE BULLETS EXCESSIVELY.

弹仓的装弹量不超过40粒。
请不要过量装弹。

1 TURN THE SELECTOR TO THE SAFE POSITION.

将单/连发选择杆拨到“安全”位置。



2 PRESS THE MUZZLE RELEASE BUTTON WHICH IS UNDER THE MUZZLE TO PULL OUT THE GUNHEAD.

按下枪嘴下面的枪头拆卸按钮拆下枪头

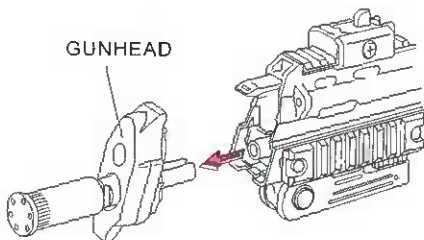
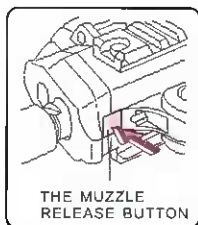

3 INSTALL THE BUTTERY INTO THE GUN AS ILLUSTRATION.

如下图方向装入电池。

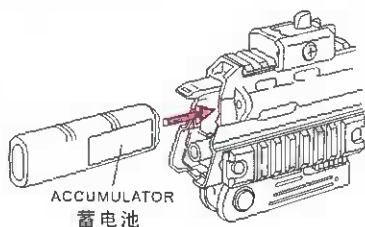

4 AIM AT THE CHAMBER AND INSTALL THE GUNHEAD.

对准枪膛装入枪头

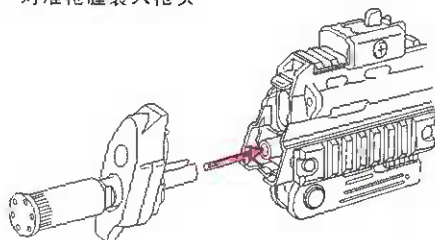

5 如何瞄准 HOW TO AIM

AIM AT THE TARGET: WHEN YOUR VISION THROUGH THE HOLES IN THE CENTER OF THE REAR SIGHT, FRONT SIGHT AND AIM AT THE TARGET. OPEN FIRE TO SHOOT

瞄准方法:当眼睛\后瞄准镜\前瞄准镜中间的小洞与射击目标成一线时,开枪射击目标。

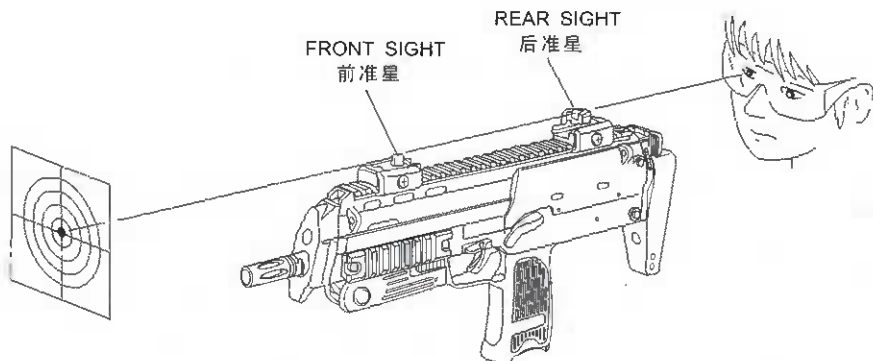

6 瞄准器 SIGHT ADJUSTMENT

ELEVATION ADJUSTMENT

TURNING THE ELEVATION ADJUSTMENT SCREW WILL MOVE THE BULLET HITTING POINT TO THE UPPER LOWER. TURN ANTI-CLOCKWISE: LOWER THE BULLET HITTING POINT. TURN CLOCKWISE: RAISE THE BULLET HITTING POINT.

WINDAGE ADJUSTMENT

TURNING THE WINDAGE ADJUSTMENT DIAL WILL MOVE THE BULLET HITTING POINT TO THE LEFT OR RIGHT

TURN ANTI-CLOCKWISE: THE BULLET HITTING POINT TO THE LEFT.

TURN CLOCKWISE: THE BULLET HITTING POINT TO THE RIGHT.

高度调节: 调节中弹点的位置高低.

逆时针: 降低中弹点位置;

顺时针: 提高中弹点位置.

偏差调节: 调节中弹点的位置偏差(左右).

逆时针: 中弹点位置偏左;

顺时针: 中弹点位置偏右.



ELEVATION ADJUSTMENT

WINDAGE ADJUSTMENT

偏差调节

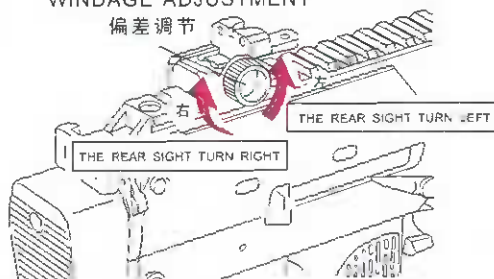

WINDAGE ADJUSTMENT

THE USE METHOD IS THE SAME AS THE ABOVE.

WARNING: THE KNOB WILL COME OUT IF TURN IT TOO MUCH.

IF NOT USING IT, PLEASE FOLD THE SIGHT TO PREVENT DAMAGE OR INJECT.

使用方法同上. 警告: 过度旋转, 旋钮会掉出来. 请在不用时将瞄准器折叠好以防损坏或受伤.

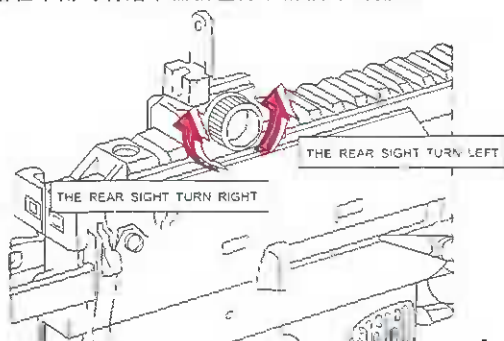
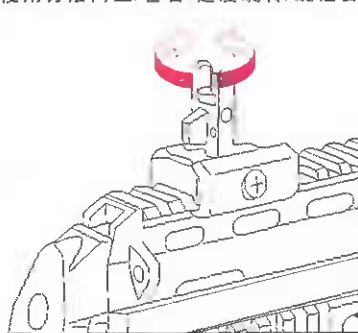

前把的操作 THE OPERATION OF THE FORE GRIP

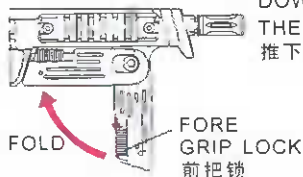
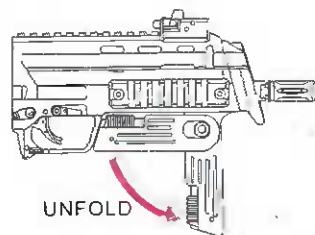

PUSH THE FORE GRIP LOCK DOWNWARDS AND FOLD THE FORE GRIP.

推下前把锁, 折叠前把.

7 阀门拉杆 COCKING LEVER

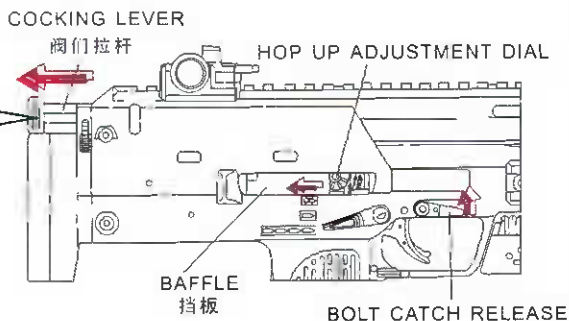
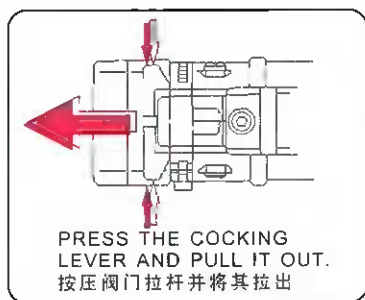

PULL THE COCKING LEVER TO PULL THE BAFFLE RIGHT AND LEFT.
THE HOP UP ADJUSTMENT DIAL IN THE EJECTION PORT EXPOSED AND RUNNING.
THE BOLT CATCH RELEASE MOVES.
拉动阀门拉杆会带动挡板左右运动, 带动HOP Up转盘转动。

8 尾托操作 THE OPERATION OF REAR GUNSTOCK

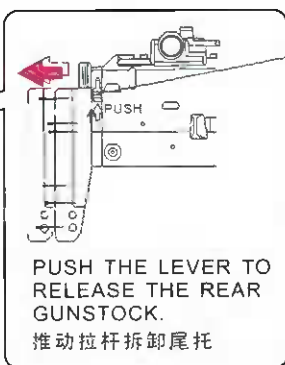
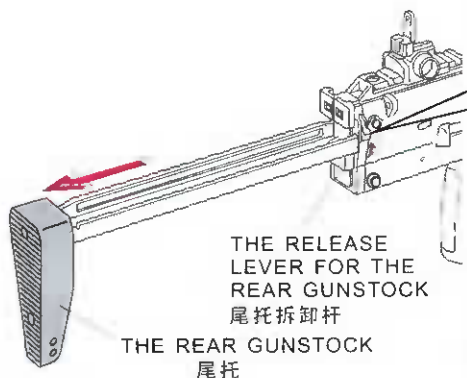

WHEN THE STOCK LOCK LEVER IS UPWARDS, THE STOCK CAN BE EXTEND BY RAISING THE STOCK RELEASE LEVER.
推起尾托拆卸按钮, 拉出尾托(前提: 尾托锁推向上)。

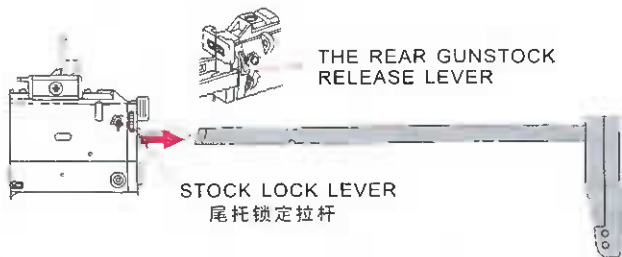

9 弹道调节 TRAJECTORY ADJUSTMENT

ADJUSTMENT PROCEDURE

KEEP PULLING THE COCKING LEVER WHILE ADJUSTING THE DIAL. IF TURN THE HOP ADJUSTMENT DIAL LITTLE BY LITTLE TO THE LEFT, HOP WILL START. THE POSITION TO WHICH BB BULLET FLIES HORIZONTALLY IS THE BEST. TURNING THE DIAL EXCESSIVELY WILL ADVERSELY AFFECTS THE TRAJECTORY OF THE BULLET.

调节程序:慢慢拉动阀门拉杆推动HOP转盘转动,直到子弹飞行轨道呈水平方向.

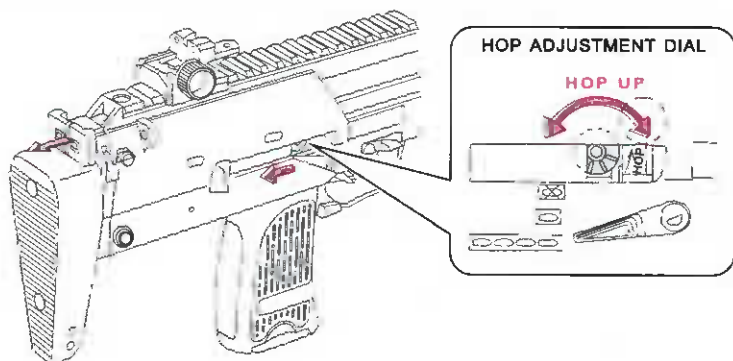

THE BEST POSITION IS WHERE THE BULLETS FLY HORIZONTALLY. AND THE LONGEST FLYING DISTANCE IS OBTAINED.

呈直线飞行. 子弹才能获得最长射程.



WHEN ABOUT 10000 ROUNDS ARE FIRED, SPRAY SILICONE OIL TO THE BORE.

发射10000发BB弹后, 将矽树脂油喷洒在枪膛里.

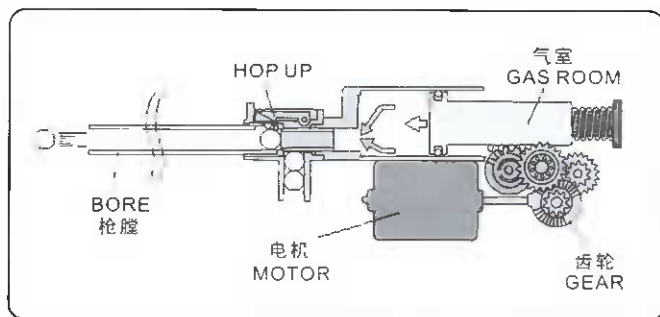

DANGER: PLASTIC PROJECTS TRAVEL AT DANGEROUS VELOCITIES. NEVER POINT OR SHOOT AT PEOPLE OR ANIMALS.

危险. 子弹以危险速度飞行. 请勿瞄准人或动物.

FOR AGES 18 YEARS AND UP- MUST BE 18 YEARS OF AGE TO PURCHASE. MINORS REQUIRE PARENT OR LEGAL GUARDIAN TO SUPERVISE OPERATING.

适合18岁以上人士- 购买者必须满18岁 未成年人在父母或合法监护人监督下操作本电动气弹枪.

10 清洁 CLEANNESS

1 MAINTENANCE WHEN BULLET SPEED BECOMES LOW

DROP A FEW DROPS OF SILICONE OIL OR TEFLON OIL INTO THE BULLET ENTRANCE. AFTER THE CLEANING, USE THE CLEANING ROD (WITH COTTON), TO REMOVE EXCESS OIL.

修护：当子弹速度太慢时
滴几滴矽树脂油或特氟隆油进枪口。
完成清洁后，用干净的棉花棒吸走多余的油脂。

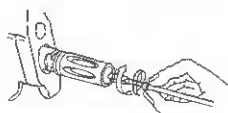
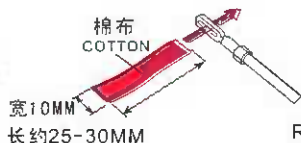
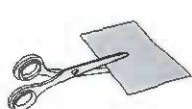
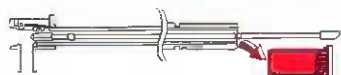

ROLL THE COTTON ON THE TOP OF THE STICK
把棉花卷在棍子一端

DAB THE MUZZLE WITH THE COTTON STICK
轻轻擦拭枪口

2 REMOVE THE CLOGGED BULLETS

(SET THE SAFETY BUTTON TO "ON" AND REMOVE THE MAGAZINE)

INSERT THE CLEANING ROD INTO THE BORE TO REMOVE THE CLOGGED BULLETS. MAKE SURE TO CLEAN THE CHAMBER WHEN THE CLOGGED BULLETS ARE REMOVED.

移走阻塞弹(将安全销拨到"ON"位置上,并移走弹仓)。将干净的棍子插入枪膛移走阻塞弹。
移走阻塞弹后请注意清洁枪膛。



11 保险丝和马达 FUSE AND MOTOR

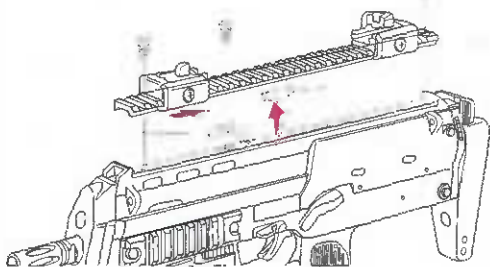

FUSE REPLACEMENT

USE A WRENCH TO REMOVE THE SCREW. MOVE BACK THE FRONT SIGHT A LITTLE. AND REMOVE THE MOUNT SUPPORT. EXCHANGE THE FUSE.

保险丝替换程序：用扳手移走螺丝，将瞄准器向后移动一点，取走支架，更换保险丝。
调节马达：在长期操作后，马达噪音增大，请进行调节马达(如上面右图所示)螺丝过度拧紧可能会损坏马达，边调节螺丝边扣动扳机，当噪音最低时停止调节。

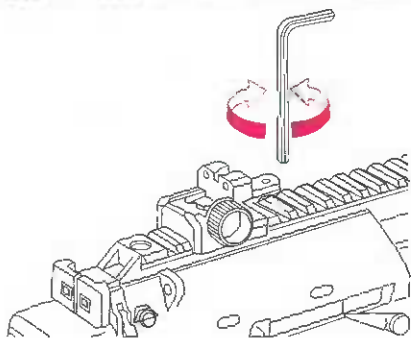

THE ADJUSTMENT OF MOTOR

ONLY WHEN THE MOTOR NOISE BECOMES HIGH AFTER OPERATIONS FOR A LONG PERIOD OF TIME, CONDUCT THE FINE ADJUSTMENT AS SHOWN. EXCESSIVE TIGHTENING OF THE SCREW MAY DAMAGE THE MOTOR. PULL THE TRIGGER WHILE ADJUSTING THE SCREWS TO THE LEFT OR RIGHT. STOP TURNING WHEN THE MOTOR IS THE QUIETEST.

THE COMPOSITION OF R-4

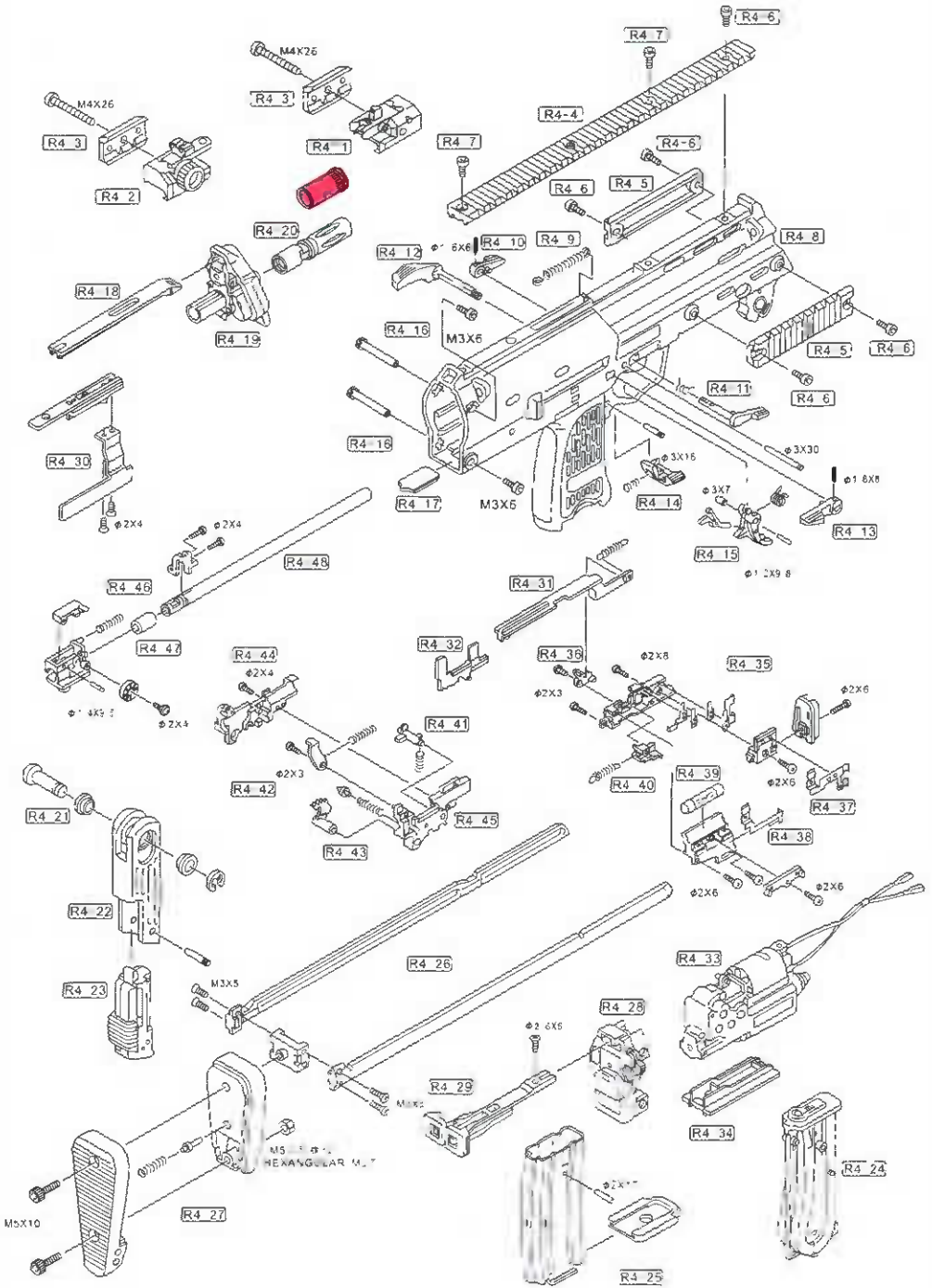

•
•

Not a Toy. 8 mm calibre model. Wear eye
protection to prevent
serious injury to the eyes. Read owner's
manual before using.
Made in China